

# ROLLER 1

## ROLLER BANNER STANDS

ROLLER BANNER STANDS



Twist out feet

Sleek anodised aluminium



Single Sided

**plex**  
DISPLAY  
banner stands

ROLLER BANNER STANDS

# ROLLER 1

# ROLLER BANNER

ROLLER 1 IS A **COMPACT AND HIGHLY PORTABLE** ROLLER STAND WITH AN **ANODISED ALUMINIUM FINISH**. IT FEATURES TWO TWIST OUT STABILISING FEET AND 3 PART **BUNGEED POLE**. AVAILABLE WITH A 2000 X 850MM GRAPHIC SIZE.

#### FEATURES

- Anodised aluminium finish
- Two twist out stabilising feet
- 3 part bungeed pole
- Visual graphic area of 2000 x 850mm
- Single sided
- Supplied with carry bag



Twist out foot



**plex**  
DISPLAY  
banner stands

COMPACT AND PORTABLE

# STAND

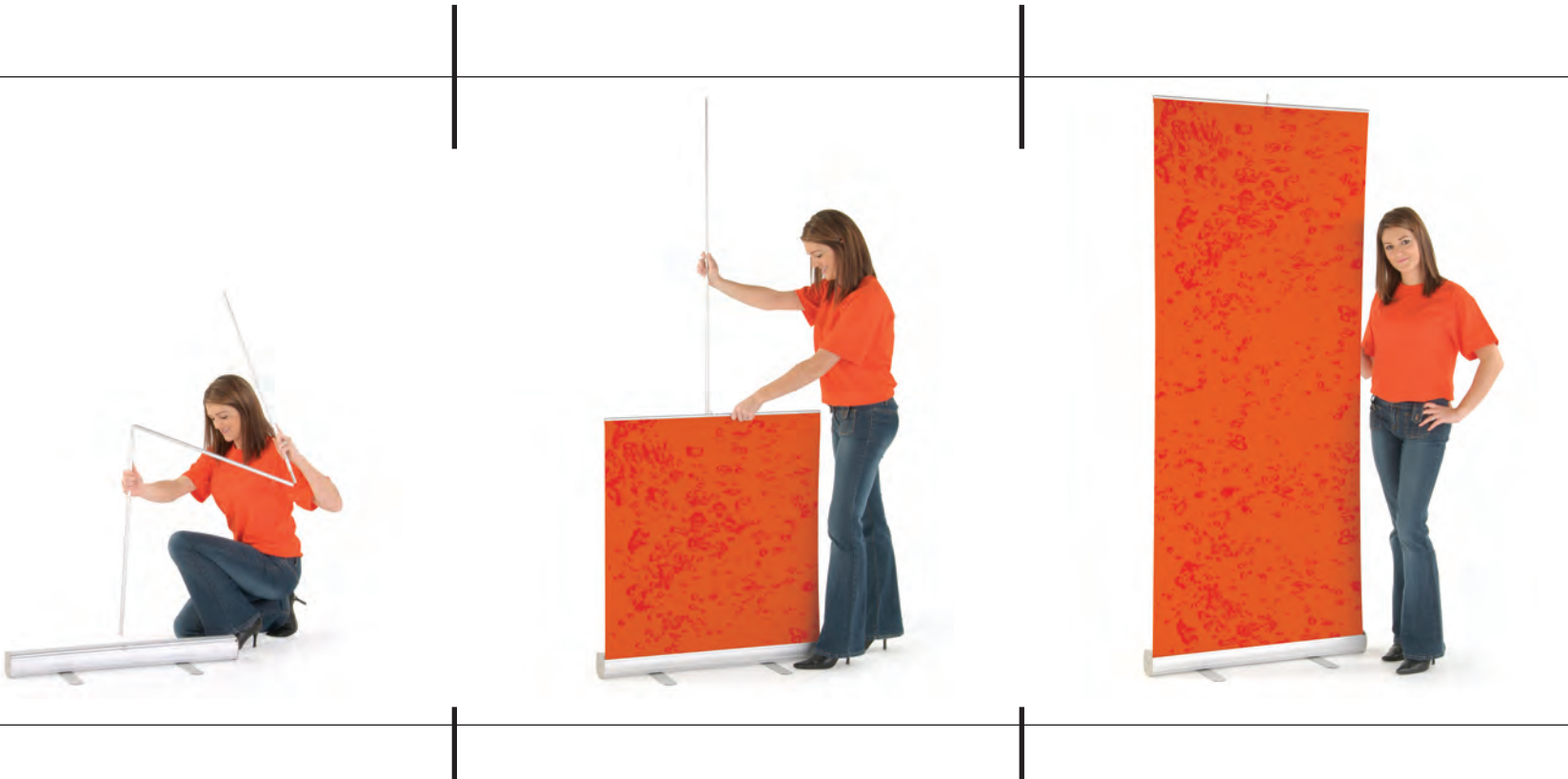

ROLLER BANNER STANDS

QUICK ASSEMBLY | SINGLE SIDED | COST EFFECTIVE | 1 YEAR WARRANTY

## SPECIFICATIONS

### SYSTEM SIZES

**Finished Graphic Panel Size**  
2200 (H) X 850 (W)mm  
(includes 200mm bleed)

### Visual Graphic Size

2000 (H) X 850 (W)mm

### Maximum Finished Graphic Panel Thickness

250 micron

### Assembled Size

2100 (H) X 865 (W) X 390 (D)mm

### Boxed Size

1050 (L) X 110 (W) X 90 (D)mm

### BOXED WEIGHT

2.40kg

## COMPONENT LIST

Roller 1 unit  
3 part bungeed pole  
Graphic hanger  
Carry bag

## ROLLER 1 - ROLLER BANNER STAND ASSEMBLY INSTRUCTIONS

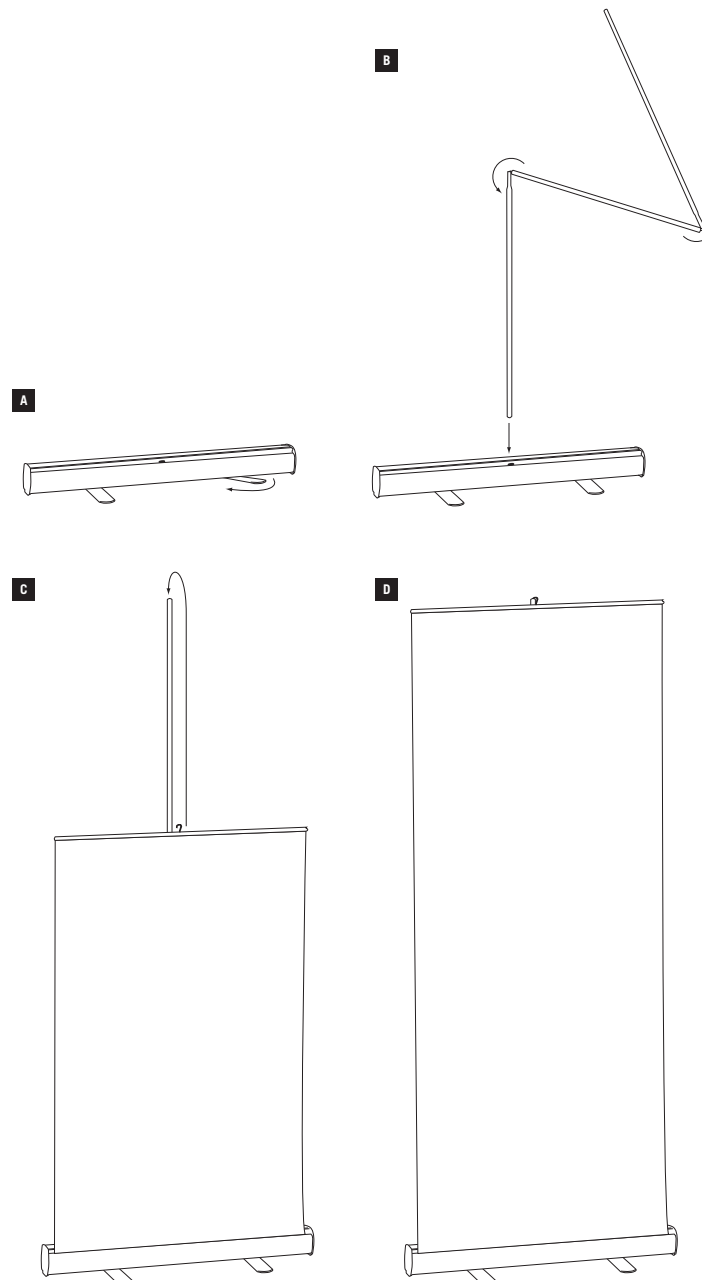

## GRAPHIC TOP ATTACHMENT

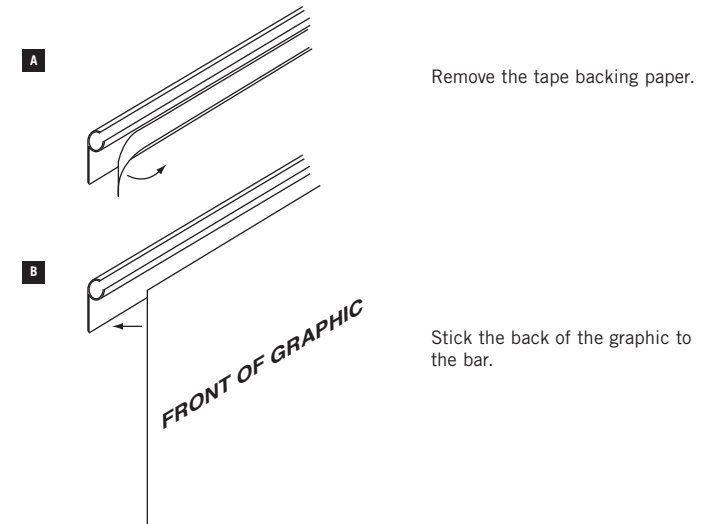

## GRAPHIC BOTTOM ATTACHMENT

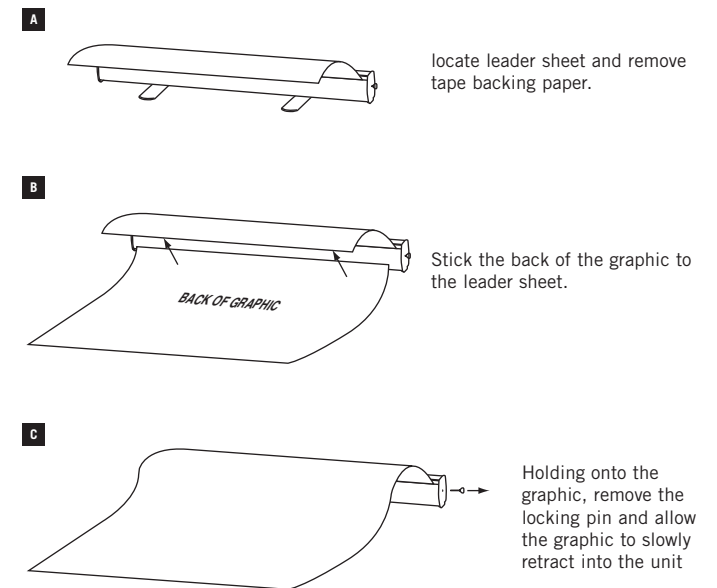

**plex**  
DISPLAY

Issue 1 - Apr 2007